

# PRODUCT DATA SHEET



## Compact Grit Removal System (ICRs)

water | wastewater | sewage

### OVERVIEW

This machine provides grit removal pre-treatment in a single packaged unit process. Influent passes through a sedimentation tank where heavy particles (sand and grit) settle to the bottom.

A horizontal shaftless grit conveying screw transports settled grit to a sump. Grit is removed from the sump via a shafted extraction screw which lifts the grit from the tank.

An optional blower can assist with fluidising the settled sand & grit, and to provide classification, for easier removal by the extraction screw. As an option, this machine can also be configured to remove fats, oils and grease.

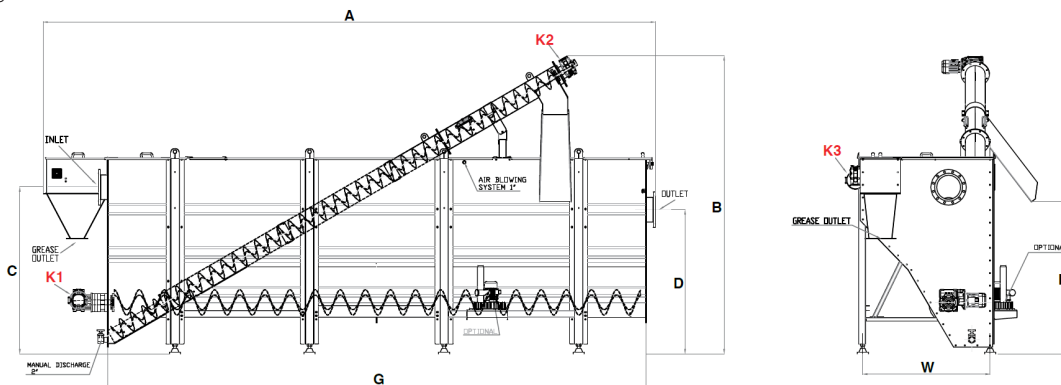

### DIMENSION TABLE

	Portate/Flow Rate L/sec	A mm	B mm	C mm	D mm	E mm	G mm	W mm	Inlet Outlet PN10	Outlet Grease mm
ICrs 3	10	4000	2400	1400	1100	1325	3000	1270	DN200	250x150
ICrs 6	20	5500	2400	1400	1100	1325	4500	1270	DN200	250x150
ICrs 8	30	7000	2400	1400	1100	1325	6000	1270	DN250	250x150
ICrs 13	45	7000	3300	1900	1600	1700	6000	1420	DN250	250x150
ICrs 17	60	7000	3300	1900	1600	1700	6000	1420	DN300	250x150
ICrs 22	80	8500	3300	1900	1600	1700	7500	1420	DN350	250x150
ICrs 28	100	11320	3300	1900	1600	1700	10500	1420	DN400	250x150
ICrs 33	120	13000	4100	2470	2265	1700	12000	2060	DN450	250x150
ICrs 42	150	16000	4100	2470	2265	1700	15000	2060	DN500	250x150

### INSTALLED POWER TABLE

	ICrs 3	ICrs 6	ICrs 8	ICrs 13	ICrs 17	ICrs 22	ICrs 28	ICrs 33	ICrs 42
K1 kW	0,55	0,55	0,55	0,55	0,55	0,55	0,55	0,75	0,75
K2 kW	0,75	0,75	1,1	1,1	0,75	0,75	0,75	0,75	0,75
K3 kW	0,37	0,37	0,37	0,37	0,37	0,37	0,37	0,37	0,55

based on machine configuration, motor power could be different

**Disclaimer:** MAK Water is continuously updating and improving its products and services, so please contact us for more detailed information or to confirm specifications. MAK Water takes no responsibility for any errors resulting from the use of information contained within this document.